

REVISION HISTORY		DATE	APPR.
A	INITIAL RELEASE	11/27/06	AP
B	ZONE C4: ADDED MISSING DIMENSIONS.	11/28/06	AP
C	1. COOLER TUBE MOVED TO OPPOSITE SIDE. 2. ZONE E6: DIM 7.68 WAS 7.14.	12/30/06	AP

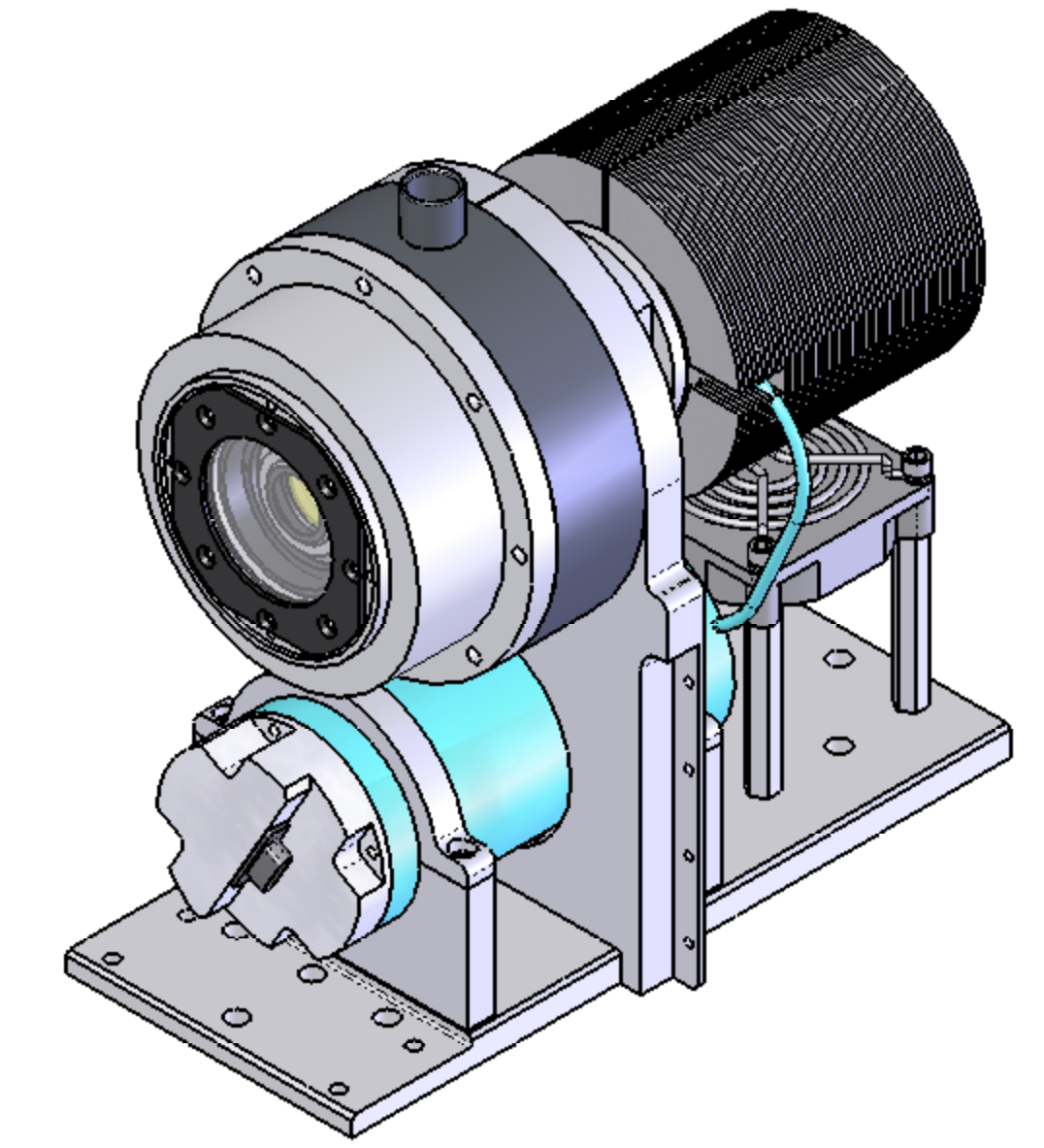
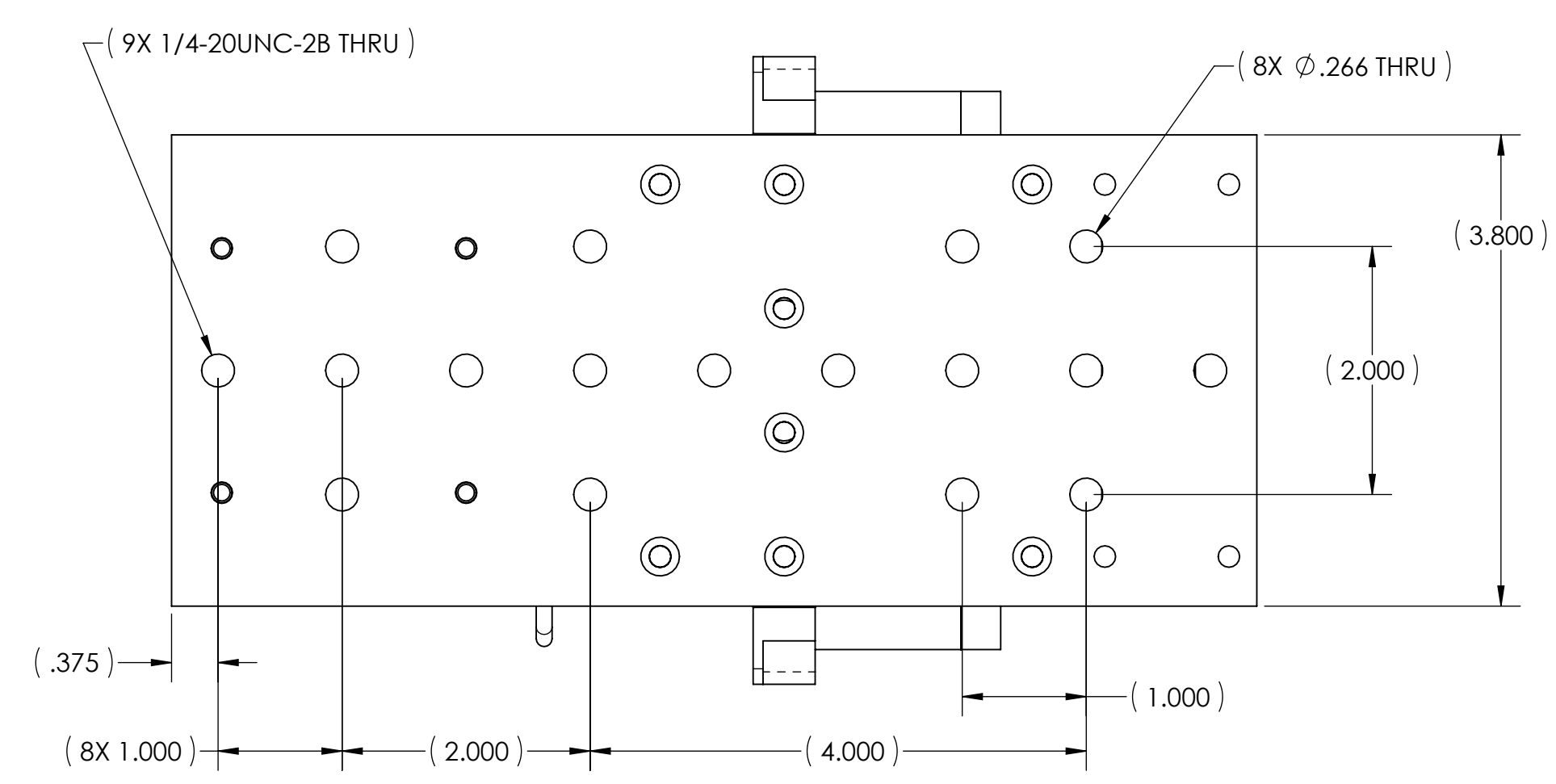
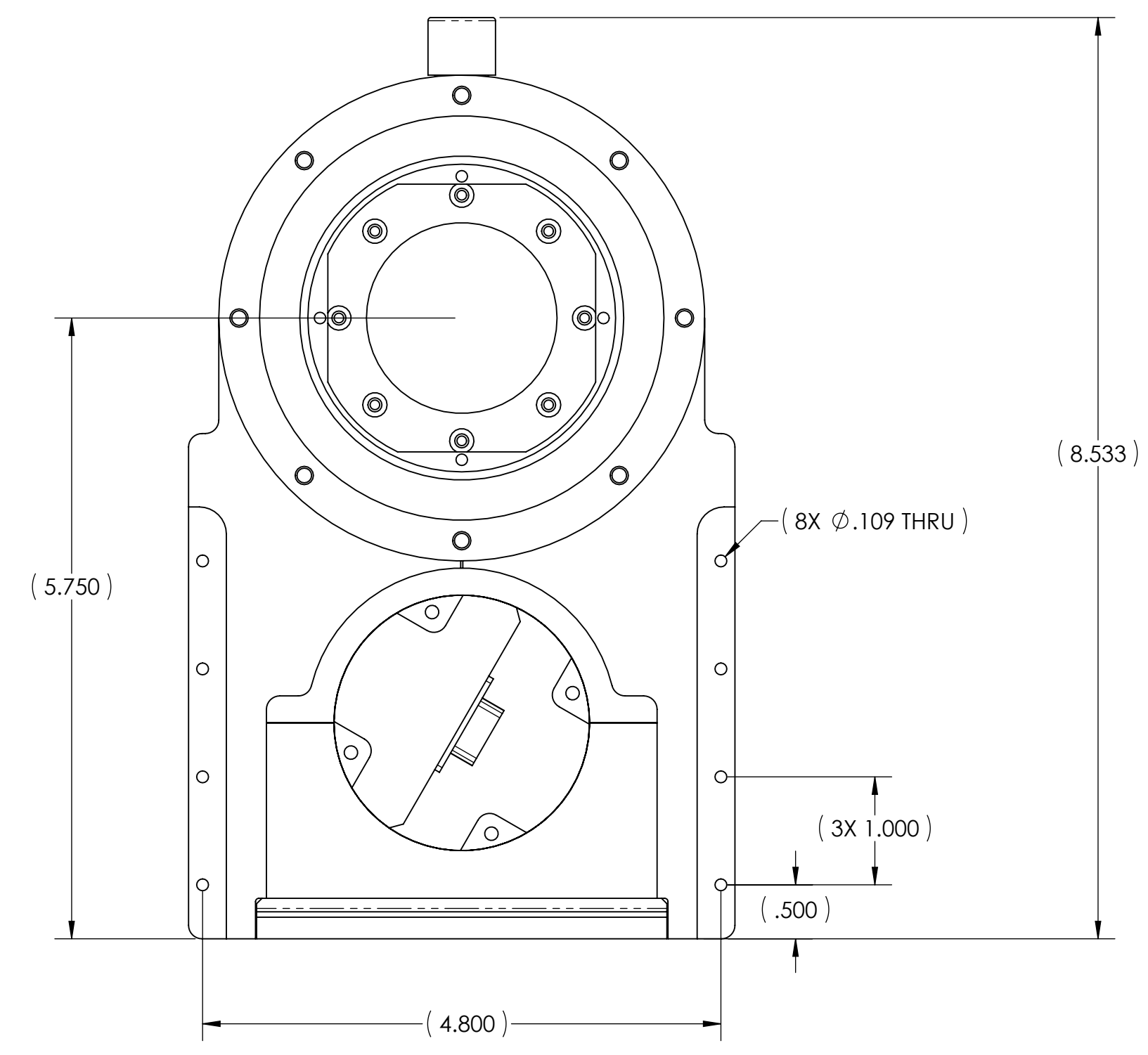
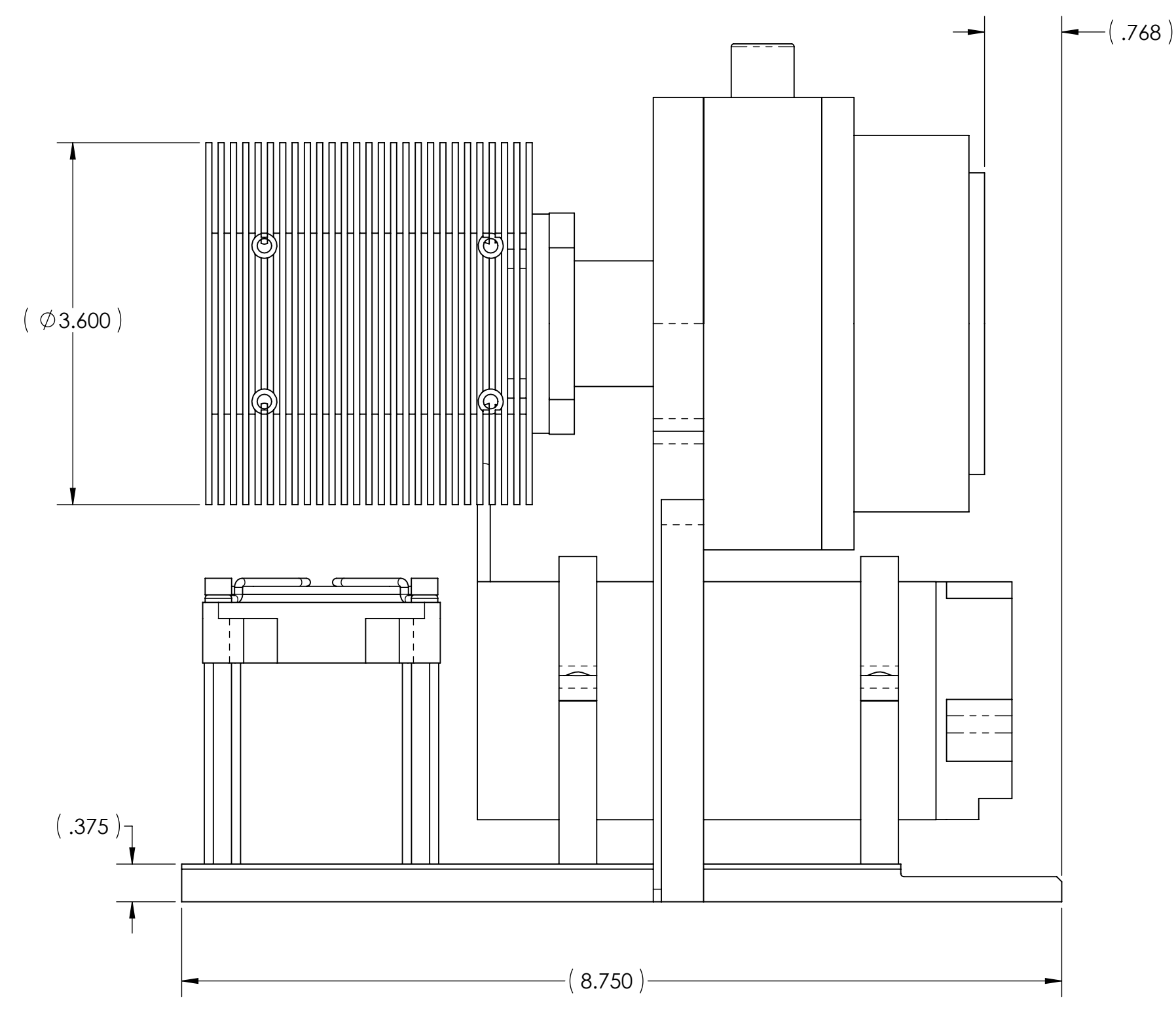
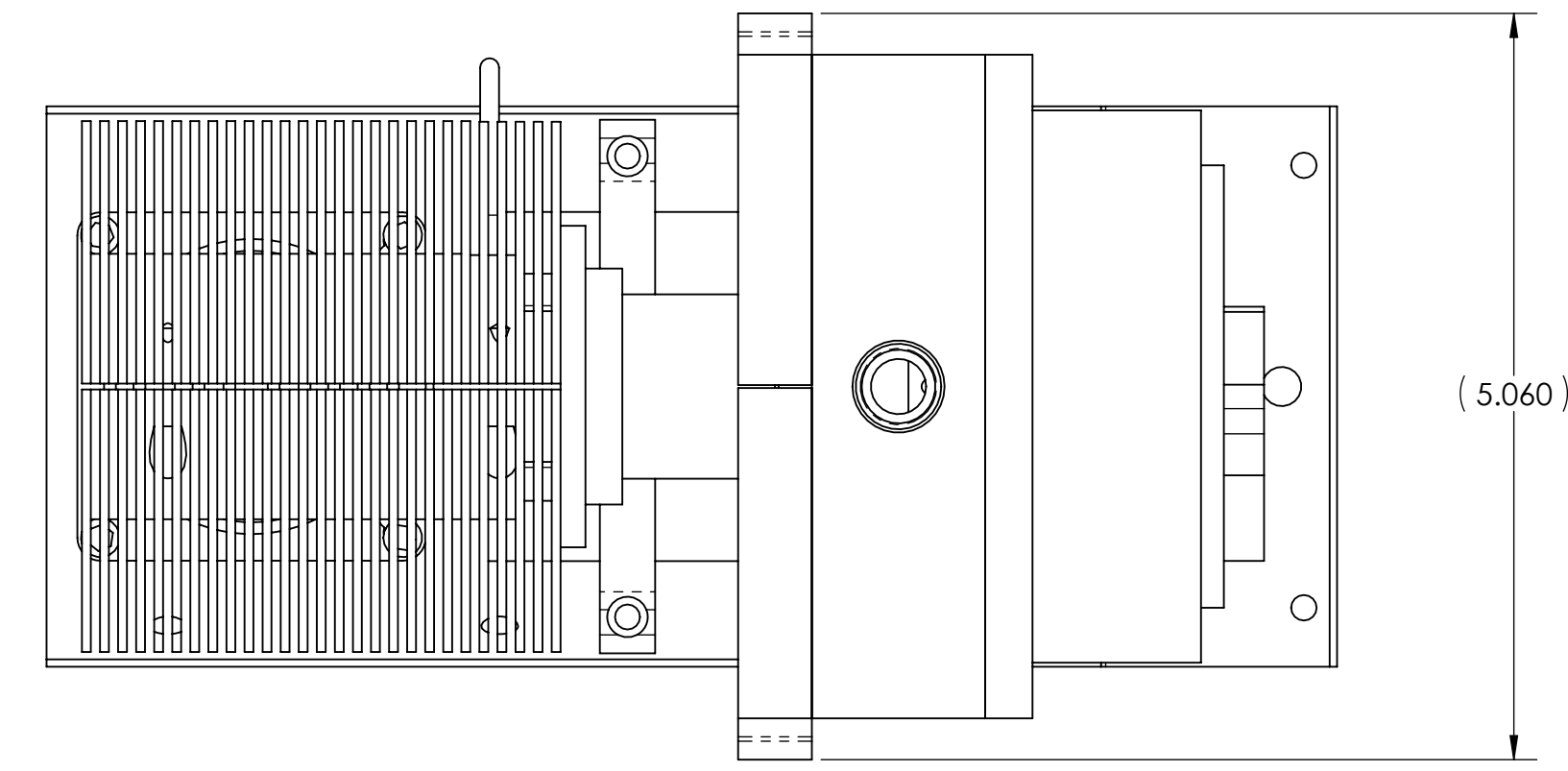

**\*1.5W Cooler is Customer supplied.**

INTERPRET GEOMETRIC TOLERANCING PER ASME Y14.5-1994	NAME	DATE	<b>CB, Inc.</b> 87 SANTA FELICIA DRIVE GOLETA, CA 93117
UNLESS OTHERWISE SPECIFIED: BREAK SHARP EDGES, D15 MAX DIMENSIONS ARE IN INCHES TOLERANCES: .XX ±.01 .XXX ±.005 ANGLES ±2° MACHINE SURFACE 125	DESIGNED	11/27/06	
PROPRIETARY AND CONFIDENTIAL THE INFORMATION CONTAINED IN THIS DRAWING IS THE SOLE PROPERTY OF CB, INC. ANY REPRODUCTION IN PART OR AS A WHOLE WITHOUT THE WRITTEN PERMISSION OF CB, INC. IS PROHIBITED.	Detailed	11/27/06	<b>DEWAR, CLOSED-CYCLE w/ 1.5W COOLER</b>
	CHECKED		<b>D DWR-CC-124-1.5W C</b>
	APPROVED		SCALE: NONE
	MATERIAL	VARIOUS	SHEET 1 OF 1
	FINISH	NONE	
	ACT WT.	.XX LBS	
	CAD GENERATED DWG		